

# Electronic Trim / Heel Detector

Stable and safe operations eliminates energy loss and load collapse.  
An evolved “semicircular canal” for ships.



The electronic trim heel detector is a device that measures the inclination of a ship.

- Compliant with IMO performance standards
- Averaging function supports accurate liquid level volume conversion
- Compatible with LNG tanks that require high-accuracy measurement

The electronic trim-heel detector senses the inclination of the ship by measuring along two axes (X and Y directions) to correct the liquid level in each tank. Trim is calculated in height, and heel shows the angle of inclination.

This electronic trim-heel detector is the central device for constructing an automated trim-heel system that maintains the attitude of the ship, controlling the trim tanks on the front and back of the ship and the heel tanks on both sides.

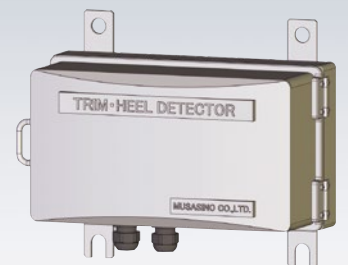

Trim	0.00 m	max 0.00	min 0.00
Heel	0.00 deg	max 0.00	min 0.00

Example

## Accurate Liquid Volume Measurement

By measuring the inclination of the ship, the liquid level of each tank can be corrected and the correct liquid volume can be calculated. This provides easily understood and accurate information, eliminating the need for frequent calculations and greatly reducing the burden on crew members.

\*The trim is calculated from the measurements of the electronic trim-heel detector along the X- or Y-axis and the distance between the draft marks on the bow and stern (distance between draft marks  $\times \tan\theta$ ). The heel measurement is calculated from the electronic trim-heel detector's measurements along the X- and Y-axes.

## Self-diagnosis Function

The power supply voltage, circuit voltage, and circuit current are constantly monitored. When a failure or abnormality in the connected sensor or control unit is detected, the LED lights up to alert the user for an immediate check.

## Angle Indication LED

An LED mounted on the board lights up when the set angle is reached.

\*For example, when  $0.1^\circ$  is set, the LED lights up when the angle is between  $-0.1^\circ$  and  $+0.1^\circ$ . The LED turns off when the angle is outside of the range.

When the electronic trim heel detector is level, four (4) LEDs will light up.

## Measurement Data Recording Function

The data measured by the sensor can be transmitted to upstream equipment.

\*Electronic Trim-Heel Detector  $\Rightarrow$  LAN-HUB  $\Rightarrow$  SCU

## Automation of Hull Attitude Control

An automated system can be constructed by adding an electronic trim heel detector to the valve and pump controls. The hull attitude is always optimized, resulting in stable, comfortable and safe navigation, and reduced fuel consumption. The burden on the crew is greatly reduced, since they only need to check and almost no operation is required.

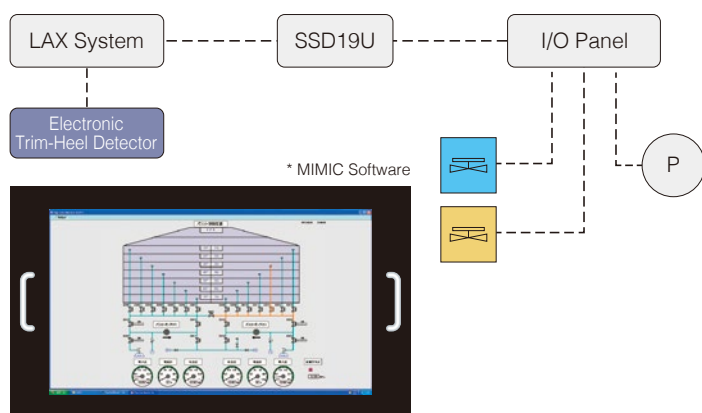

## Stable Operation in Automation

The accuracy and responsiveness of the electronic trim-heel detector measurements are of great importance, since the detector plays a central role in the operation of an automated control system. In the unlikely event that a problem – such as abnormal measurements – occurs, the control of the entire system will be affected, so redundancy is necessary. To provide that redundancy, the electronic trim-heel detector should be changed to a type equipped with two sensors.

## Operating Principle

A capacitive MEMS sensor built in to the electronic trim-heel detector senses changes in inclination and calculates the angle.

## Electronic Trim-Heel Detector Line

Standard: Sensor accuracy is  $\pm 0.2$  degrees

High-Spec: Sensor accuracy is  $\pm 0.05$  degrees

Standard-2 set: Equipped with two sensors with an accuracy of  $\pm 0.2$  degrees

For normal specifications, select either the standard or high-spec electronic trim-heel detector.

## Specifications

Ambient Operating Temperature	0~55°C
Explosion-proof Grade	Not Applicable
Protection Class	IP44
Sensor Accuracy	$\pm 0.2^\circ$ / Standard Type $\pm 0.05^\circ$ / High-Accuracy Type
Interface	LAN
Power Supply Voltage	DC12~24V
Current Consumption	100 mA
Measurement Range	$\pm 10^\circ$ / Standard Type $\pm 5^\circ$ / High-Accuracy Type
Measurement Accuracy	$\pm 0.2^\circ$ / Standard Type $\pm 0.05^\circ$ / High-Accuracy Type
Resolution	0.001°
External Dimensions(WxHxD)	280 x 240 x 134 mm
Weight	Approx. 2 kg



## MUSASINO CO., LTD.

□ Head Office  
1-2-15 MinamiYukigaya, Ota-ku, Tokyo, 145-0066  
Tel.+81-3-3726-4413 Fax.+81-3-3726-1557  
E-mail : sales@musasino.co.jp / service1@musasino.co.jp

<https://www.musasino.biz>

Distributor: